



HYDRAULIC HOSE REELS

Spring Rewind Dual Hose Reels

To handle dual 1/4" through 3/4" I.D. hose.

Dual-hose spring rewind reels are available in two frame configurations. The N series has a narrow frame and compact mounting base. The rollformed channel frame for heavy-duty applications is available in the 600 series, and must be specified. (Delete prefix N for Rollformed Channel Frame.)

Series N600 and 600 reels have two swivel joint inlets and two outlet risers to handle two equal lengths of hose. Hoses can be different diameters, in which case the larger hose diameter determines the capacity of the reel.

Rewind:

A heavy-duty spring motor provides self-contained rewind power. A non sparking ratchet assembly locks the reel when the desired length of hose has been payed out. A pull on the hose unlocks the reel and the spring motor retracts the hose. A declutching arbor is provided to prevent damage from reverse winding.

Inlets:

Standard inlets are 90° swivel joints with 1/2" female NPT threads.

Outlets:

Standard outlets are 1/2" female NPT threads.

Other sizes and/or threads can be furnished and must be specified.

Operating Pressures & Temperatures:

These reels operate at pressures to 3000 psi and handle product temperatures from -20° to +225° F.

Rollers:

All models are supplied with a 4-way roller assembly. Roller position must be specified.

Hose Stop:

A hose stop should be used to prevent damage to rollers and nozzles and to permit adjustment of free hose length.

HYDRAULIC
TOOLS &
ACCESSORIES

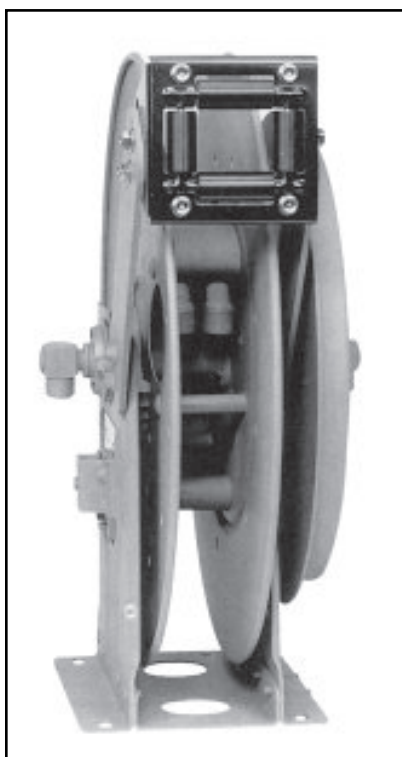

Series N600

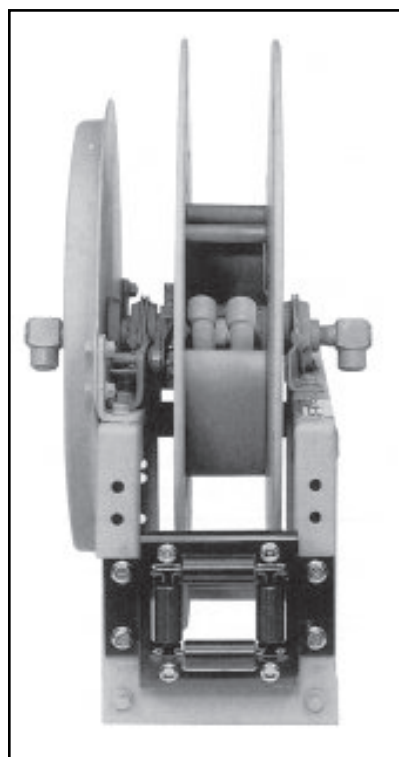

Series 600

30 Travis Avenue, PO Box 1690, Binghamton, NY 13902-1690
Phone 607-773-2405 • Fax 607-773-2414 • www.linemenssupply.com

Dimensions and capacities

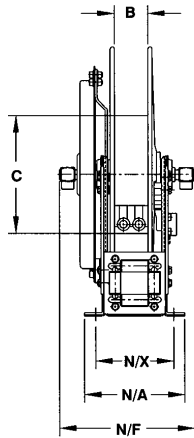

Series N600 Narrow Frame

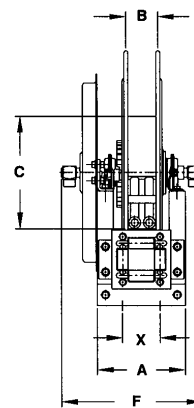
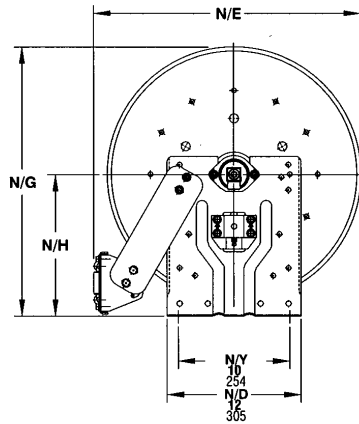

Series 600 Rollformed Channel Frame

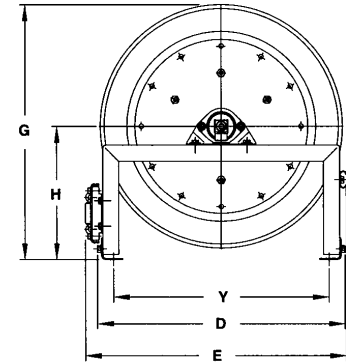

HYDRAULIC TOOLS & ACCESSORIES

Roller Positions Available

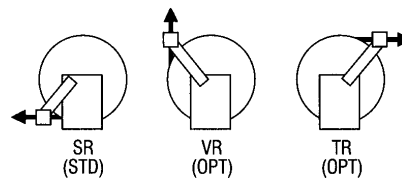

BE SURE TO CHECK DIMENSIONS AND WEIGHTS PRIOR TO ORDERING.

I.D. (in)	Hose Capacity of Reel feet				No.	Reel Dimensions Inches															Approx. Weight lb.	Roller Assy. Supplied on St. Models		
	1/4"	3/8"	1/2"	3/4"		x, y indicate mounting holes																		
O.D. (in)	5/8"	3/4"	7/8"	1-9/32"	Delete prefix N for Rollformed Channel Frame	A	N/A	B	C	D	E	N/E	F	N/F	G	N/G	H	N/H	N/X	X	Y	NET	SHIP	
2/75	2/75	2/50			N617-25-26B	10.25	11	5	15.5	25	26.12	25.25	15.0	13.75	25.88	26	13.5	13.62	9	5.5	22	93	128	N205
2/35	2/35	2/20	-		N615-19-20C	8.25	9	3	10.5	18	19.5	20.75	13.0	11.75	19.75	20	10.38	10.62	7	3.5	15	63	98	N203
2/50	2/50	2/25	-		N617-19-20J	10.25	11	5	10.5	18	19.5	20.75	15.0	13.75	19.75	20	10.38	10.62	9	5.5	15	66	101	N205
2/65	2/60	2/30	-		N615-23-24B	8.25	9	3	10.5	23.25	24.38	23.75	13.0	11.75	23.88	24	12.5	7	3.5	87	122	N203		
2/100	2/85	-	-		N617-25-26A	10.25	11	5	15.5	25	26.12	25.25	15.75	14.5	25.88	26	13.5	13.62	9	5.5	22	120	155	N205
-	-	2/100	2/50		+618-30-31A	11.25	-	6	15.5	28.5	-	21.75	-	31.38	-	17	-	-	6.5	25.5	130	165	R206	

Specifications subject to change.

Notes:

1. Reel models and capacities shown are for standard drag applications; for vertical lift or constant tension application consult factory.
 2. Many other sizes, from standard components, available on request.
- + Standard inlets on this model reel are 90° swivel joints with 1" NPT threads, standard outlets are 3/4" female NPT threads.

30 Travis Avenue, PO Box 1690, Binghamton, NY 13902-1690
Phone 607-773-2405 • Fax 607-773-2414 • www.linemenssupply.com